

EPFULL (European Patents FULL TEXT)

Subject Coverage All patent-relevant areas of science and technology, i.e., all classes of the International Patent Classification.

File Type Full Text

Features

Thesaurus	International Patent Classification (/IPC)				
Alerts (SDIs)	Weekly				
CAS Registry Numbers®	<input type="checkbox"/>	Page Images	<input type="checkbox"/>	STN AnaVist	<input type="checkbox"/>
Keep & Share	<input checked="" type="checkbox"/>	SLART	<input checked="" type="checkbox"/>	STN Easy	<input checked="" type="checkbox"/>
Learning Database	<input type="checkbox"/>	Structures	<input type="checkbox"/>	STN Viewer	<input checked="" type="checkbox"/>

Record Content

- Bibliographic data and full text of published European patent applications and examined granted European patents and bibliographic records for PCT (Patent Cooperation Treaty) applications transferred to the EPO since 1978.
- Database records comprise all documents published for one European application number. All data corresponds to the European Patent Bulletin and is always in a current state.
- Records contain bibliographic data, titles in English, French and German, the original abstract plus the English translation of German and French abstracts and legal status information. For applications full text of detailed description and claims are given in one of EPO's official languages English, German or French; for examined granted patents the description is given in the original language, claims are available in all three languages.
- For each document the complete legal status history is maintained. All legal status events are fully searchable, including former names, addresses, and titles if they were reassigned. INPADOCDB legal status is available for display too.
- Patent and non-patent literature citations, given by the applicant within the description of a patent document as well as by the examiner in the search report, are made available for search and display.
- First page images are present for documents which were updated or entered the database after January 2006.

File Size More than 3.2 million records, more than 370,000 images (04/12)

Coverage 1978–present

Updates Weekly

Language English, French, German

Database Producers	European Patent Office Vienna Sub Office P.O. Box 90 Austria Phone: +43 1 52126-0 Fax: +43 1 52126-5491	LexisNexis Univentio BV Galileiweg 8 2333 BE Leiden The Netherlands Phone: (+31) 88-6390000 E-Mail: customersupport@univentio.com
	Copyright Holders	

**Database
Supplier**

FIZ Karlsruhe
STN Europe
P.O. Box 2465
76012 Karlsruhe
Germany
Phone: +49 7247 808-555
Fax: +49 7247 808-259
E-Mail: helpdesk@fiz-karlsruhe.de
Copyright Holder

Sources

Patent applications and granted patents published by the European Patent Office.

User Aids

- Online Helps (HELP DIRECTORY lists all help messages available)
 - STNGUIDE
-

Clusters

- AEROTECH
 - ALLBIB
 - AUTHORS
 - CORPSOURCE
 - ENGINEERING
 - FULLTEXT
 - HPATENTS
 - PATENTS
 - PNTTEXT
 - [STN Database Clusters](#) information (PDF)
-

Pricing

See the [STN Price List](#) or enter HELP COST at an arrow prompt.

Search and Display Field Codes

If multiple search terms are linked with and AND-operator, all terms are searched in the complete database record, i.e. in all publications referring to one application. For a search in a specific publication of the record, connect the search term and the patent kind code with the (L)-proximity operator, e.g.

S HOLOGRA?(S)?LASER? (L) EPA1/PK limits the search to European applications EPA1.

Fields that allow left truncation are indicated by an asterisk (*).

General Search Fields

Search Field Name	Search Code	Search Examples	Display Codes
Basic Index* (contains single words from abstract (AB), claims (CLM), detailed description (DETD), and title (TI) fields)	None or /BI	S PRINTED-CIRCUIT BOAR S STRIPPING DEVICE/BI S HOLOGRA?(S)?LASER?	ABDE, ABEN, ABFR, CLMDE, CLMEN, CLMFR, DETDDE, DETDEN, DETDFR, TIEN, TIDE, TIFR
Abstract*	/AB	S PLATIN? CATALYST?/AB	ABDE, ABEN, ABFR
Accession Number	/AN	S 2000:100003/AN	AN
Agent (2)	/AG	S ROBERT WEYDERT/AG	AG
Agent Address (2)	/AGA	S MANNHEIM/AGA	AG
Agent Address Old	/AGAO	S GULDE/AGAO AND BERLIN/AGAO	LSEF
Agent Number	/AGN	S 241/AGN	AGN
Agent, City (2)	/AG.CTY	S AACHEN/AG.CTY	AG
Agent, Country (WIPO code and text)	/AG.CNY	S AUSTRIA/AG.CNY	AG
Agent, Street (2)	/AG.STR	S SEELBERGSTRASSE/AG.STR	AG
Application Country (WIPO code and text)	/AC	S EP/AC	AI
Application Date (1)	/AD	S AD=JAN 2003	AI
Application Number (3)	/AP	S EP1996-300599/AP	AI
Application Number Previously Filed Application	/PFAP	S FR2007-386/PFAP	PFAI
Application Year (1)	/AY	S 1999-2000/AY	AI
Claims*	/CLM	S OFFICE CHAIR/CLM S BUEROSTUHL/CLM S PROCEDE DE TEINTURE/CLM	CLMEN, CLMDE, CLMFR
Data Update Date (1)	/DUPD	S DUPD=FEB 2003	DUPD
Data Update Week (1)	/DUPW (or /UW)	S 200409/DUPW	DUPW
Designated States (WIPO code and text)	/DS	S BELGIUM/DS S BE/DS	DS
Document Type (code and text)	/DT	S P/DT	DT
Entry Date (1)	/ED	S ED>=AUG 2007	ED
Entry Date Patent (1)	/EDP	S EDP = DEC 2004	EDP
Field Availability	/FA	S CLMDE/FA	FA
Filing Country Previously Filed Application	/PFAC	S FR/PFAC	PFAI
Filing Date Previously Filed Application	/PFAD	S 20070119/PFAD	PFAI
Filing Year Previously Filed Application	/PFAY	S 2008/PFAY	PFAI
Graphic Image Size (1)	/GIS	S L1 AND 200-300/GIS	GIS
Graphic Image Type	/GIT	S TIF/GIT	GIT

General Search Fields (cont'd)

Search Field Name	Search Code	Search Examples	Display Codes
International Patent Classification (contains ICM, ICS, ICA, ICI, IPCI, IPCR) (4)	/IPC	S A01B0001-02/IPC S H05B0006-36+NT/IPC S H05B0006-36-H05B0006-44/IPC	IPC
Inventor	/IN (or /AU)	S MAYER ADOLF/IN	IN
Inventor Address	/INA	S MUENCHEN MURNAUER/INA	IN
Inventor Address Old (2)	/INAO	S KRANZ/INAO	LSEP
Inventor Address, City (2)	/IN.CTY	S WIEN/IN.CTY	IN
Inventor Address, Country (WIPO code and text)	/IN.CNY	S DE/IN.CNY	IN
Inventor Address, Street (2)	/IN.STR	S BERLINER?/IN.STR	IN
Inventor, Comment	/IN.COM	S THE OTHER INVENTORS HAVE AGREED TO WAIVE THEIR ENTITLEMENT TO DESIGNATION./IN.COM	IN
IPC (International Patent Classification)	/IC	S H05K007-14/IC	IC
IPC Edition (1)	/IC.VER	S 7/IC.VER	IC.VER
IPC Main Group Range Searchable (1,5)	/MGR	S B29K/ICI(T)20-30/MGR	ICM, ICS
IPC Sub Group Range Searchable (1,5)	/SGR	S H05K007/ICM(S)10000-20000/SGR	ICM, ICS
IPC, Action Date (1)	/IPC.ACD	S 13 JAN 2006/IPC.ACD	IPC.TAB
IPC, Additional	/ICA	S F16H061-14/ICA	ICA, IC
IPC, Index (complementary)	/ICI	S B29K105-08/ICI S A61K031:40/ICI	ICI, IC
IPC, Initial	/IPCI	S H01L0023-29/IPCI	IPCI
IPC, Keyword Terms	/IPC.KW	S C12N0009/IPC (S) /IPC.KW	IPC.TAB
IPC, Main	/ICM	S A01B043-00/ICM	ICM
IPC, Old	/ICO	S A01B043-00/ICO	LSEP
IPC, Secondary	/ICS	S D21C011-04/ICS	ICS, IC
IPC, Version from IPC	/IPC.VER	S 200601/IPC.VER	IPC.TAB
Language of Filing (WIPO code and text)	/LAF	S FR/LAF S FRENCH/LAF	LAF
Language of Procedure (WIPO code and text)	/LAP	S GERMAN/LAP	LAP
Language (WIPO code and text)	/LA	S DE/LA S GERMAN/LA	LA
Legal Status Code (code and text)	/LSC	S EPB235/LSC	LSEP
Legal Status Code Text	/LSTX	S REFUSAL OF APPLICATION/LSTX	LSEP
Legal Status Country (WIPO code and text)	/LSCY	S BE/LSCY	LSEP
Legal Status Date in Force (1)	/LSDF	S LSDF=1978	LSEP
Legal Status Publication Date (1)	/LSD	S 20050202/LSD	LSEP
Legal Status Update Date (1)	/UPLS	S UPLS=AUG 2005	UPLS
Licensee Address	/LIA	S US/LIA S LYONS/LIA	LI
Licensee Address Old (2)	/LIAO	S INTERMUNE CALIFORNIA/LIAO	LSEP
Licensee Address, City (2)	/LI.CTY	S LONDON W3/LI.CTY	LI
Licensee Address, Country (2) (WIPO code and text)	/LI.CNY	S CALI.CNY	LI
Licensee Address, Street (2)	/LI.STR	S AM HARDTWALD/LI.STR	LI
Licensee Date (1)	/LID	S 20010901-20010930/LID	LI
Licensee Designated States Concerned (WIPO code and text)	/LIDS	S BE/LIDS S CYPRUS/LIDS	LI

General Search Fields (cont'd)

Search Field Name	Search Code	Search Examples	Display Codes
Licensee EPO Number	/LIN	S 7510/LIN	LI
Licensee Kind	/LIK	S L1 AND EXCLUSIVE LICENCE/LIK	LI
Licensee Name (2)	/LI	S CANDESCENT TECHNOLOGIES CORPORATION/LI	LI
Main Claim*	/MCLM	S KUNSTSTOFFABFALL?/MCLM	MCLM
Number of Claims (1)	/CLMN	S CLMN<=10	CLMN
Number of Detailed Description (1)	/DETN	S DETN>1000	DETN
Opponent Address, City	/OP.CTY	S THOUSAND OAKS/OP.CTY	OP
Opponent Address, Country (WIPO code and text)	/OP.CNY	S US/OP.CNY	OP
Opponent Address, Street (2)	/OP.STR	S DEHAVILLAND DRIVE/OP.STR	OP
Opponent Agent (2)	/OPAG	S VOGELSANG/OPAG	OP
Opponent Agent Address (2)	/OPAGA	S MUENCHEN/OPAGA	OP
Opponent Agent Address Old (2)	/OPAGAO	S (ABB SCHWEIZ)/OPAGAO	LSEP
Opponent Agent Number	/OPAGN	S 72473/OPAGN	OP
Opponent Agent, City	/OPAG.CTY	S ABINGDON/OPAG.CTY	OP
Opponent Agent, Country (WIPO code and text)	/OPAG.CNY	S DENMARK/OPAG.CNY	OP
Opponent Agent, Street (2)	/OPAG.STR	S BERLINER ALLEE/OPAG.STR	OP
Opponent Assignee (complete information)	/OPA	S AMGEN/OPA AND OAKS/OPA	OP
Opponent Name (2)	/OP	S AMGEN/OP	OP
Opponent Number	/OPN	S 80/OPN	OP
Opponent Old (2)	/OPAO	S FUJI/OPAO	OP
Opposition Date (1)	/OPD	S 19970101-19981231/OPD	OP
Opposition Kind	/OPK	S OPPOSITION WITHDRAWN/OPK	OP
Opposition, Date of Rejection (1)	/OP.RD	S 2003 AUGUST/OP.RD	OP
Opposition, Date of Termination (1)	/OP.TD	S 20041017/OP.TD	OP
Patent Assignee (2)	/PA (or /CS)	S BASF LACKE/PA	PA
Patent Assignee Address (2)	/PAA	S IRELAND/PAA	PA
Patent Assignee Address Old	/PAAO	S UNILEVER/PAAO AND LONDON/PAAO	LSEP
Patent Assignee Number	/PAN	S 631710/PAN	PAN
Patent Assignee, City (2)	/PA.CTY	S MANCHESTER/PA.CTY	PA
Patent Assignee, Country (WIPO code and text)	/PA.CNY	S NL/PA.CNY	PA
Patent Assignee, Designated States (WIPO code)	/PADS	S GB/PADS	PA
Patent Assignee, Street (2)	/PA.STR	S VICTORIA STREET/PA.STR	PA
Patent Country (WIPO code and text)	/PC	S WO/PC	PI
Patent Information Publication Type	/PIT	S EPB2 AMENDED PATENT/PIT	PIT
Patent Kind Code	/PK	S EPB1/PK	PI
Patent Number (3)	/PN (or /PATS)	S EP140038/PN S EP-----140038/PN	PI
Priority Country (WIPO code and text)	/PRC	S AUSTRALIA/PRC	PRAI
Priority Country, Original	/PRCO	S BELGIUM/PRCO	PRAO
Priority Date (1)	/PRD	S JP/PRC AND 19880101-19880331/PRD	PRAI
Priority Date, First (1)	/PRDF	S 20030109/PRDF	PRAI
Priority Number (3)	/PRN	S US1986-817951/PRN	PRAI
Priority Number, Old (3)	/PRN.OLD	S AT1994-1352/PRN.OLD	LSEP
Priority Number, Original	/PRNO	S US003859 P/PRNO	PRAO

General Search Fields (cont'd)

Search Field Name	Search Code	Search Examples	Display Codes
Priority Year (1)	/PRY	S PRY=2003	PRAI
Priority Year, First (1)	/PRYF	S PRYF=2003	PRAI
Publication Date (1)	/PD	S PD=5 FEB 2004	PI
Publication Year (1)	/PY	S 1999-2000/PY	PI
Referenced Non-Patent Literature (6)	/REN	S SCIENCE/REN	REN
Referenced Patent Country (WIPO code and text) (6)	/RPC	S US/RPC	REP
Referenced Patent Number	/RPN	S EP566226/RPN	REP
Related Application Country (WIPO code and text)	/RLC	S EP/RLC	RLI
Related Application Date (1)	/RLD	S RLD>JAN 2003	RLI
Related Application Number	/RLN	S EP1995-104274/RLN	RLI
Related Application Type	/RLT	S EARLIER APPLICATION/RLT	RLI
Related Patent Country (WIPO code and text)	/RLPC	S EP/RLPC	RLI
Related Patent Number (6)	/RLPN	S EP662724/RLPN	RLI
Title (contains TIEN, TIDE, TIFR)*	/TI	S ABISOLIERGERAET/TI S DISPOSITIF DE DENUDAGE/TI	RLI TIEN, TIFR, TIDE
Title Language (ISO code and text)	/TL	S L1 AND ENGLISH/TL	TL
Title Old	/TIO	S DEVICE FOR MANAGING/TIO	LSEP
Update Date (1)	/UP	S UP=JAN 2005	UP
Update Date Legal Status (1)	/UPLS	S UPLS=AUG 2005	UPLS

(1) Numeric search field that may be searched with numeric operators or ranges.

(2) Search with implied (S) proximity is available in this field.

(3) Either STN or Derwent format may be used.

(4) A thesaurus is available in this field.

(5) Only valid for IPC version 1-7.

(6) Contains INID56 and applicant-cited references.

Super Search Fields

Enter a super search field to execute a search in one or more fields that may contain the desired information. Super search fields facilitate crossfile and multifile searching. EXPAND may not be used with super search fields. Use EXPAND with the individual field codes instead.

Search Field Name	Search Code	Fields Searched	Search Examples	Display Codes
Application Number Group Short Basic Index	/APPS /SBI	/AP, /PRN /AB, /MCLM, /TI	S EP1995-104274/APPS S ANATOMIE/SBI	AI, PRAI AB, TI, MCLM

IPC Thesaurus

The classifications, validity and catchwords for the main headings and subheadings from the current (8th) edition of the WIPO International Patent Classification (IPC) manual are available. The classifications from the previous editions (1-7) are also available as separate thesauri. To EXPAND and SEARCH in the thesauri for editions 1-7, use the field code followed by the edition number, e.g. /IPC2, for the 2nd edition. Catchwords are included only in the thesauri for the 8th, 7th, 6th, and 5th editions.

IPC Thesaurus (cont'd)

Code	Content	Examples
ADVANCED (ADV)	Advanced Codes for the Core Level IPC Code	E A61K0006-02+ADVANCED/IPC
ALL	All Associated Terms (BT, SELF, NT, RT)	E C01C003-00+ALL/IPC
BRO (MAN)	Complete Class	E C01C+BRO/IPC
BT	Broader Term (BT, SELF)	E C01F001-00+BT/IPC
CORE (COR)	Core Codes for the Advanced Level IPC Code	E G08C0019-22+CORE/IPC
ED	Complete title of the SELF term and IPC manual edition	E C01F001-00+ED/IPC
HIE	Hierarchy Term (Broader and Narrower Term) (BT, SELF, NT)	E C01B003-00+HIE/IPC
INDEX	Complete title of the SELF term	E C01F001-00+INDEX/IPC
KT	Keyword Term (catchwords) (SELF, KT)	E CYANOGEN+KT/IPC
NEXT	Next Classification	E C01C001-00+NEXT5/IPC
NT	Narrower Terms (SELF, NT)	E C01C+NT/IPC
PREVn	Previous Classification (n=1,2...)	E C01C001-12+PREV10/IPC
RT (SIB)	Related Terms (SELF, RT)	E C01C003-20+RT/IPC
TI	Complete Title of the SELF Term and Broader Terms (BT, SELF)	E C01F001-00+TI/IPC

DISPLAY and PRINT Formats

Any combination of formats may be used to display or print answers. Multiple codes must be separated by spaces or commas, e.g., D L1 1-5 TI AU. The fields are displayed or printed in the order requested.

The information of the latest publication is displayed by default. To display the content for all levels of the record you can combine all display fields and formats with the qualifier .M except FA, FAM, CFAM, LS, LS2, SCAN, and TRIAL.

For displaying a particular publication of a database record, you can simply add for certain display field the kind code to the appropriate display format, e.g. ALL.A1. Fields that allow this are indicated by a number (2).

Hit-term highlighting is available for all fields. Highlighting must be ON during SEARCH to use the HIT, KWIC, and OCC formats.

Format	Content	Examples
AB (AB.M, ABS) (2)	Abstract for all Publication Levels in all Languages	D AB.M
ABDE (ABDE.M) (2)	Abstract for all Publication Levels in German	D ABDE.M
ABEN (ABEN.M) (2)	Abstract for all Publication Levels in English	D ABEN.M
ABFR (ABFR.M) (2)	Abstract for all Publication Levels in French	D ABFR.M
AG	Agent	D AG
AGN	Agent Number	D AGN
AI (AP) (1)	Application Information	D AI
AI.M	Application Information for all Publication Levels	D AI.M
AN	Accession Number	D AN
CLM (2)	Claims	D CLM
CLM.PK(n) (2)	Claim Number n for a Certain Publication Level in all Languages	D CLM.B1(1)
CLMDE (2)	Claims in German	D CLMDE
CLMDE.PK(n) (2)	Claim Number n for a Certain Publication Level in German	D CLMDE.A1(1)
CLMDE(n)	Claim n in German	D CLMDE(15)
CLMEN (2)	Claims in English	D CLMEN
CLMEN.PK(n) (2)	Claim Number n for a Certain Publication Level in English	D CLMEN.B1(34)
CLMEN(n)	Claim n in English	D CLMEN(3)
CLMFR (2)	Claims in French	D CLMFR
CLMFR.PK(n) (2)	Claim Number n for a Certain Publication Level in French	D CLMFR.A9(24)
CLMFR(n)	Claim n in French	D CLMFR(14)

DISPLAY and PRINT Formats (cont'd)

Format	Content	Examples
CLMN (2)	Number of Claims	
DETD (2)	Detailed Description	D DETD
DETDDE (2)	Detailed Description in German	D DETDDE
DETDDE.PK(n)	Detailed Description in German for a certain Publication Level, Paragraph n	D DETDDE.A9(16)
DETDDE(n)	Detailed Description in German, Paragraph n	D DETDDE(103)
DETDEN (2)	Detailed Description in English	D DETDEN
DETDEN.PK(n)	Detailed Description in English for a certain Publication Level, Paragraph n	D DETDEN.B1(25)
DETDEN(n)	Detailed Description in English, Paragraph n	
DETDFR (2)	Detailed Description in French	D DETDFR
DETDFR.PK(n)	Detailed Description in French for a certain Publication Level, Paragraph nr	D DETDFR.B2(13)
DETDFR(n)	Detailed Description in French, Paragraph n	D DETDFR(45)
DETN (2)	Number of Detailed Descriptions	D DETN
DS	Designated States	
DT (TC)	Document Type	
DUPD	Data Update Date	D DUPD
DUPW (UW)	Data Update Week	
ED	Entry Date	D ED 1-10 L3
FA (F.A.M)	Field Availability for all Publication Levels	D FA 1-20
GI	Graphic Image	D GI
GIS	Graphic Image Size	D GIS
GIT (3)	Graphic Image Type	D GIT
IC	IPC	
IC.VER	IPC Edition	D IC.VER
ICA	IPC, Additional	
ICI	IPC, Index	
ICM	IPC, Main	
ICS	IPC, Secondary	
IN	Inventor	D TI IN 5
IPC	International Patent Classification	D IPC
IPC1	IPC, Initial	D IPC1
LA	Language	
LAF	Language of Filing	
LAP	Language of Procedure	
LI	Licensee Name	D LI
LSEP (LSEP.M)	EPFULL Legal Status, with history if present	D LSEP
MCLM (2,3)	Main Claim	D MCLM
OP	Opponent Name	D OP
PA	Patent Assignee	D PA
PAN	Patent Assignee Number	D PAN
PFAI (PFAP)	Previously Filed Application Information	D PFAI
PI (PN) (1)	Patent Information	D PI
PIT	Patent Information Publication Type	D PIT
PRAI (PRN) (1)	Priority Information	D PRAI
PRAO (PRNO)	Priority Number, Original Format	D PRAO
REN	Referenced Non-Patent Literature	D REN
RENA	Applicant Non-Patent Citation	D RENA
REP	Referenced Patent	D REP
REPA	Applicant Patent Citation	D REPA
RLI	Related Application Information	D RLI

DISPLAY and PRINT Formats (cont'd)

Format	Content	Examples
TI TIDE TIEN TIFR TL UP	Title (contains TIEN, TIFR, TIDE) Title in German Title in English Title in French Title Language Update Date	D TIDE D TIEN 1-3
ALL (DALL) (1,2) ALLG (1) IALL (1,2) IALLG (1) APPS (1) BIB (1,2) IBIB (1,2) BIBLS (1) BRIEF (1,2) BRIEFG (1) IBRIEF (1,2) IBRIEFG (1) IC IND (IPC) IPC.TAB MAX (ALL.M) (1) MAXG (ALLG.M) (1) IMAX (IALL.M) (1) IMAXG (IALLG.M) (1) FAM CFAM LS (3) LS2 (3) RE TRIAL (TRI, SAMPLE, SAM, FREE) SCAN (4) STD (1,2) STDG ISTD (1,2) ISTDG TX (2)	AN, ED, UP, DUPD, DUPW, TI, IN, PA, PAN, AG, AGN, LAF, LA, LAP, TL, DT, PIT, PI, DS, AI, PFAI, RLI, PRAI, REC, IPC, OP, LI, AB, DETD, CLM ALL, plus graphic image ALL, indented with text labels IALL, plus graphic image AI, PRAI AN, ED, UP, DUPD, DUPW, TI, IN, PA, PAN, AG, AGN, LAF, LA, LAP, TL, DT, PIT, PI, DS, AI, PFAI, RLI, PRAI, REC BIB, indented with text labels BIB, LSEP AN, ED, UP, DUPD, DUPW, TI, IN, PA, PAN, AG, AGN, LAF, LA, LAP, TL, DT, PIT, PI, DS, AI, PFAI, RLI, PRAI, REC, IPC, AB, MCLM BRIEF, plus graphic image BRIEF, indented with text labels IBRIEF, plus graphic image ICM, ICS IC.VER, ICM, ICS, ICA, ICI, IPCR, IPCI IPC, IPC.KW, IPC.ACD, IPC.VER in tabular format AN, ED, UP, DUPD, DUPW, TI, IN, PA, PAN, AG, AGN, LAF, LA, LAP, TL, DT, PIT, PI, DS, AI, PFAI, RLI, PRAI, REN, RENA, REP, REPA, PC, OP, LI, AB, DETD, CLM, LSEP (for all Publication Levels) MAX, plus graphic image MAX, indented with text labels IMAX, plus graphic image AN, table of patent family information (from the INPADOCDB database) Condensed family format (from the INPADOCDB database) Legal Status (from the INPADOCDB database) Legal Status (from the INPADOCDB database), detailed version with display headers REN, REP, RENA, REPA AN, ED, UP, DUPD, DUPW, TI, PK, FA, DETN, CLMN, GIS, GIT, (for all Publication Levels) TI (random display without answer number) AN, ED, UP, DUPD, DUPW, TI, IN, PA, PAN, AG, AGN, REC, LAF, LA, LAP, TL, DT, PIT, PI, DS, AI, PFAI, PRAI, RLI, IPC STD, plus graphic image STD, indented with text labels ISTD, plus graphic image DETD, CLM	D ALL D ALLG D IALL D BIB D IBIB D BIBLS D BRIEF D IND D MAX D IMAX D CFAM D RE D SCAN D STD D ISTD D TX
HIT KWIC OCC	Hit term(s) and field(s) Up to 50 words before and after hit term(s) (KeyWord-In-Context) Number of occurrences of hit term(s) and field(s) in which they occur	D HIT D KWIC D OCC

(1) Application and patent numbers are available in STN and Derwent format. The format for DISPLAY, PRINT, SELECT, and SORT is set using the SET PATENT command. STN is the default format. Enter SET PAT DERWENT to change to the Derwent format. To reset to the STN format, enter SET PAT STN.

(2) You can combine this display field with the qualifier .PK (Patent Kind Code) to display the content for a certain publication level of a record, e.g. STD.A1

(3) Custom display only.

(4) SCAN must be specified on the command line, i.e., D SCAN or DISPLAY SCAN.

EPFULL

SELECT, ANALYZE, and SORT Fields

The SELECT command is used to create E-numbers containing terms taken from the specified field in an answer set.

The ANALYZE command is used to create an L-number containing terms taken from the specified field in an answer set.

The SORT command is used to rearrange the search results in either alphabetic or numeric order of the specified field(s).

You can combine all fields except FA with the qualifier .M to SELECT/ANALYZE the content of all publication levels.

Field Name	Field Code	ANALYZE/ SELECT (1)	SORT
Abstract	AB	Y	N
Abstract in English	ABEN	Y (2)	N
Abstract in French	ABFR	Y (2)	N
Abstract in German	ABDE	Y (2)	N
Accession Number	AN	Y	Y
Agent	AG	Y	Y
Agent Name and Address	AGDD	Y	N
Agent, Country	AG.CNY	Y	Y
All Claims for a Certain Publ. Level in German	CLMDE.PK (3)	Y	N
All Claims for a Certain Publication Level in English	CLM.PK (3)	Y	N
All Claims for a Certain Publication Level in English	CLMEN.PK (3)	Y	N
All Claims for a Certain Publication Level in French	CLMFR.PK (3)	Y	N
All Claims for all Publication Levels in English	CLMEN.M	Y	N
All Claims for all Publication Levels in French	CLMFR.M	Y	N
All Claims for all Publication Levels in German	CLMDE.M	Y	N
Applicant Non Patent Citation	RENA	Y (4)	N
Applicant Patent Citation	REPA	Y (5)	N
Application Country	AC	Y	Y
Application Date	AD	Y	Y
Application Information	AI (AP, APPS)	Y	Y
Application Information for all Publication Levels	AI.M	Y	Y
Application Number Previously Filed Application	PFAP (PFAI)	Y	Y
Application Year	AY	Y	Y
Claim in English	CLMEN	Y	N
Claim in French	CLMFR	Y	N
Claim in German	CLMDE	Y	N
Claim n in English	CLMEN(n)	Y	N
Claim n in French	CLMFR(n)	Y	N
Claim n in German	CLMDE(n)	Y	N
Claim Number n for a Cert. Publication Level in English	CLMEN.PK(n) (3)	Y	N
Claim Number n for a Cert. Publication Level in French	CLMFR.PK(n) (3)	Y	N
Claim Number n for a Cert. Publication Level in German	CLMDE.PK(n) (3)	Y	N
Claim Number n for a Cert. Publication Level. in all Languages	CLM.PK(n) (3)	Y	N
Claims	CLM	Y	N
Complete Detail. Description for Certain Publication Levels	DETD.PK	Y	N
Data Update Date	DUPD	Y	Y
Data Update Week	DUPW (UW)	Y	Y
Designated States	DS	Y	N
Detailed Description	DETD	Y	N
Detailed Description for all Publication Levels	DETD.M	Y	N
Detailed Description in English	DETDEN	Y	N
Detailed Description in English, Paragraph n	DETDEN(n)	Y	N
Detailed Description in French	DETDFR	Y	N

SELECT, ANALYZE, and SORT Fields (cont'd)

Field Name	Field Code	ANALYZE/ SELECT (1)	SORT
Detailed Description in French, Paragraph n	DETDFR(n)	Y	N
Detailed Description in German	DETDDE	Y	N
Detailed Description in German, Paragraph n	DETDDE(n)	Y	N
Document Type	DT (TC)	Y	Y
Entry Date	ED	Y	Y
EPFULL Legal Status	LSEP	Y	Y
Field Availability	FA	Y	N
Filing Country Previously Filed Application	PFAC	Y	Y
Filing Date Previously Filed Application	PFAD	Y	Y
Filing Year Previously Filed Application	PFAY	Y	Y
Graphic Image Size	GIS	Y	N
Graphic Image Type	GIT	Y	N
Inventor	IN	Y	Y
Inventor Address	INA	Y	N
Inventor Address, Complete Information	INDD	Y	N
Inventor Address, Country	IN.CNY	Y	N
Inventor, Comment	IN.COM	Y	N
IPC (ICM, ICS, ICA, ICI, IPCI, IPCR)	IPC	Y	N
IPC (Main and Secondary)	IC	Y	N
IPC Edition	IC.VER	Y	N
IPC, Advanced Level Symbols	IPC.A	Y	N
IPC, Advanced Level Symbols for Invention	IPC.AI	Y (6)	N
IPC, Core Level Symbols	IPC.C	Y (6)	N
IPC, Core Level Symbols for Invention	IPC.CI	Y (6)	N
IPC, Initial	IPC.I	Y (6)	N
IPC, Main	ICM	Y	Y
IPC, Secondary	ICS	Y	Y
Language	LA	Y	Y
Language of Filing	LAF	Y	Y
Language of Procedure	LAP	Y	Y
Legal Status Code	LSC	Y	N
Legal Status Country	LSCY	Y	N
Legal Status Date in Force	LSDF	Y	N
Legal Status Publication Date	LSD	Y	N
Legal Status Update Date	UPLS	Y	N
Licensee Address, Country	LI.CNY	Y	N
Licensee Date	LID	Y	N
Licensee Designated States Concerned	LI.DS	Y	N
Licensee EPO Number	LIN	Y	N
Licensee Kind	LIK	Y	N
Licensee Name	LI	Y	N
Main Claim	MCLM	Y	N
Main Claim in English	MCLMEN	Y	N
Main Claim in French	MCLMFR	Y	N
Main Claim in German	MCLMDE	Y	N
Number of Claims	CLMN	Y	N
Number of Paragraphs in DETD	DETN	Y	N
Occurrence Count of Hit Terms	OCC	N	Y
Opponent Address	OPA	Y	N
Opponent Address, City	OP.CTY	Y	N
Opponent Address, Country	OP.CNY	Y	N
Opponent Address, Street	OP.STR	Y	N
Opponent Agent	OPAG	Y	N
Opponent Agent Address	OPAGA	Y	N
Opponent Agent Number	OPAGN	Y	N
Opponent Agent, Country	OPAG.CNY	Y	Y
Opponent Name	OP	Y	N

SELECT, ANALYZE, and SORT Fields (cont'd)

Field Name	Field Code	ANALYZE/ SELECT (1)	SORT
Opponent Name and Address	OPDD	Y	N
Opponent Number	OPN	Y	N
Opposition Date	OPD	Y	N
Opposition Kind	OPK	Y	N
Opposition, Date of Rejection	OP.RD	Y	N
Opposition, Date of Termination	OP.TD	Y	N
Paragraph Number n of Det. Description Cert. Publication	DETD.PK(n)	Y	N
Patent Assignee	PA	Y	Y
Patent Assignee Address	PAA	Y	N
Patent Assignee for all Publication Levels	PAM	Y	Y
Patent Assignee, Country	PACNY	Y	Y
Patent Assignee, Designated States	PADS	Y	N
Patent Assignee, Number	PAN	Y	Y
Patent Country	PC	Y	Y
Patent Information Publication Type	PIT	Y	Y
Patent Kind Code	PK	Y	Y
Patent Number	PN (PI)	Y	Y
Patent Number Group	PATS	Y	N
Pre-IPC8 Symbols from the ICM and first IPC8 values from 2006-present	IPC.F	Y (6)	Y
Priority Country	PRC	Y	Y
Priority Country, Original	PRCO	Y	Y
Priority Date	PRD	Y	Y
Priority Number	PRN (PRAI)	Y	Y
Priority Number for all Publication Levels	PRNO	Y	Y
Priority Year	PRY	Y	Y
Priority Year, First	PRYF	Y	Y
Publication Date	PD	Y	Y
Publication Number Previously Filed Application	PFPN	Y	Y
Publication Year	PY	Y	Y
Referenced Non-Patent Literature	REN	Y	N
Referenced Patent Number	RPN (REP)	Y	N
Related Application Country	RLC	Y	N
Related Application Number	RLN	Y	N
Related Application Type	RLT	Y	N
Related Patent Country	RLPC	Y	N
Related Patent Number	RLPN	Y	N
Subclass	SCL	Y (7)	N
Subclass Additional	SCLA	Y (8)	N
Subclass Group	SCG	Y (7)	N
Subclass Group Additional	SCGA	Y (8)	N
Subclass Group Main	SCGM	Y (9)	N
Subclass Group Secondary	SCGS	Y (10)	N
Subclass Main	SCLM	Y (9)	N
Subclass Secondary	SCLS	Y (10)	N
Title	TI	Y (11) (default)	Y
Title in English	TIEN	Y (12)	Y
Title in French	TIFR	Y (12)	Y
Title in German	TIDE	Y (12)	Y
Title Language	TL	Y	Y
Update Date	UP	Y	Y

- (1) HIT may be used to restrict terms extracted to terms that match the search expression used to create the answer set, e.g., SEL HIT TI.
- (2) Appends /AB to the terms created by SELECT.
- (3) PK = Patent Kind Code.
- (4) Appends /REN to the terms created by SELECT.
- (5) Appends /RPN to the terms created by SELECT.
- (6) Appends /IPC to the terms created by SELECT.
- (7) Appends /IC to the terms created by SELECT.
- (8) Appends /ICA to the terms created by SELECT.
- (9) Appends /ICM to the terms created by SELECT.
- (10) Appends /ICS to the terms created by SELECT.
- (11) Selects or analyzes TIEN, TIDE, and TIFR with /TI appended to the terms created by SELECT.
- (12) Appends /TI to the terms created by SELECT.

Sample Records

DISPLAY MAXG (STN format)

```

AN      2006:70066      EPFULL  EDP 20070314  ED 20070314  UP 20080326
        DUPD 20080326 DUPW 200813
TIEN    Motor-fastening mechanism and cam device.
TIFR    Dispositif de fixation d'un moteur et dispositif a came.
TIDE    Vorrichtung zur Befestigung eines Motors und Nockenvorrichtung.
IN      Kato, Heizaburo, 1434-1 Hansei Kikukawa-shi, Shizuoka Shizuoka, JP;
        Hotaka, Hideki, c/o Sankyo Seisakusho Co. 2290 Honjo Kikukawa-shi,
        Shizuoka Shizuoka, JP
PA      Sankyo Seisakusho Co., 37-3, Tabata-Shinmachi-3-chome, Kita-ku, Tokyo,
        JP
PAN     1993931
AG      Finnie, Peter John, et al, Gill Jennings & Every LLP  Broadgate House  7
        Eldon Street, London EC2M 7LH, GB
AGN     79521
DT      Patent
LAF     English
LA      English
LAP     English
TL      German; English; French
PIT     EPA1 Application published with search report
PI      EP 1762772          A1 20070314
DS      DE FR GB IT
AI      EP 2006-120418      A   20060911
PRAI    JP 2005-264195      A   20050912
IPCI    F16M0013-00        [I,A ]
        F16M0013-00        [I,C*]

```

ABEN

A motor-fastening mechanism fastens an output shaft of a motor and an input shaft of a driven member to each other. The motor-fastening mechanism has a fastening section which fastens the output shaft of the motor and the input shaft of the driven member relatively immovably, a motor-attachment member which is attached to the motor, an engaged section which is provided on either one of the motor-attachment member and the driven member, and an engaging section which is provided on the other of the motor-attachment member and the driven member and which is engaged to the engaged section such that displacement of the output shaft in a rotating direction thereof is regulated.

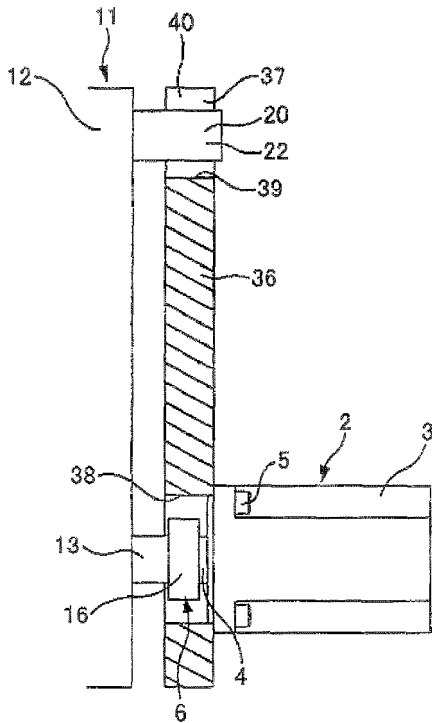

Fig. 3

RENA (1) Coupling, Kikai Sekkei , 19970101, volume 41, number 1, pages 60-64
(APP) [0002]

DETDEN

Field of the Invention

[0001] The present invention relates to a motor-fastening mechanism and a cam device.

Background to the Invention

[0002] Regarding a method for fastening to an input shaft of a driven member an output shaft of a motor which rotates with high precision such as a servo ...

CLMEN

1. A motor-fastening mechanism for fastening an output shaft of a motor and an input shaft of a driven member to each other, comprising:

a fastening section that fastens the output shaft of the motor and the input shaft of the driven member relatively immovably;

a motor-attachment member that is attached to the motor;

an engaged section that is provided on either one of the motor-attachment member and the driven member; and

an engaging section that is provided on the other of the motor-attachment member and the driven member and that is engaged to the engaged section such that displacement of the output shaft in a rotating direction thereof is regulated.

...

AN 2006:70066 EPFULL EDP 20070314 ED 20080813 UP 20090722
 DUPD 20090722 DUPW 200930
 TIEN Motor-fastening mechanism and cam device.
 TIFR Dispositif de fixation d'un moteur et dispositif a came.
 TIDE Vorrichtung zur Befestigung eines Motors und Nockenvorrichtung.
 IN Kato, Heizaburo, 1434-1 Hansei Kikukawa-shi, Shizuoka Shizuoka, JP;
 Hotaka, Hideki, c/o Sankyo Seisakusho Co. 2290 Honjo Kikukawa-shi,
 Shizuoka Shizuoka, JP
 PA Sankyo Seisakusho Co., 37-3, Tabata-Shinmachi-3-chome, Kita-ku, Tokyo,
 JP
 PAN 1993931
 AG Finnie, Peter John, et al, Gill Jennings & Every LLP Broadgate House 7
 Eldon Street, London EC2M 7LH, GB
 AGN 79521
 DT Patent
 LAF English
 LA English
 LAP English
 TL German; English; French
 PIT EPB1 Granted patent
 PI EP 1762772 B1 20080813
 DS DE FR GB IT
 AI EP 2006-120418 A 20060911
 PRAI JP 2005-264195 A 20050912
 REP DE 10200328 A1 (INID56)
 JP 2004098789 A (INID56)
 JP 2004199828 A (INID56)
 US 6021992 A (INID56)
 IPCI F16M0013-00 [I,A]
 F16M0013-00 [I,C*]
 REPA JP 2004098789 A (APP) [0004]
 RENA (1) KIKAI SEKKEI, Coupling, Mechanical Design , 19970101, volume 41,
 number 1, pages 60-64 (APP) [0002]

DETDEN

Field of the Invention

[0001] The present invention relates to a motor-fastening mechanism and a cam device,

Background to the Invention

[0002] Regarding a method for fastening to an input shaft of a driven member an output shaft of a motor which rotates with high precision such as a servo

...

CLMEN

1. A motor-fastening mechanism for fastening an output shaft (4) of a motor (2) and an input shaft (13) of a driven member (11) to each other, comprising:

EPFULL

a fastening section (6) that fastens the output shaft (4) of the motor and the input shaft (13) of the driven member (11) relatively immovably,

a motor-attachment member (36) that is attached to the motor (2); characterised in that it further comprises:

an engaged section (37) and an engaging section (20) that, when engaged with each other, are suitable for absorbing misalignment that occurs on a fastened portion where the output shaft (4) and the input shaft (13) are fastened,

the engaged section (37) being provided on either one of the motor-attachment member (36) and the driven member (11),

the engaging section (20) being provided on the other of the motor-attachment member (36) and the driven member (11) and being engaged to the engaged section (37) such that rotation of the motor (2) around the rotational axis of its output shaft (4) is constrained.

...

CLMFR

1. Mecanisme de fixation d'un moteur destine a fixer un arbre de sortie (4) d'un moteur (2) et un arbre d'entree (13) d'un element mene (11) l'un a l'autre, comportant :

une section de fixation (6) qui fixe l'arbre de sortie (4) du moteur et l'arbre d'entree (13) de l'element mene (11) de facon relativement immobile ;

un element (36) d'attache de moteur qui est attache au moteur (2) ; caracterise en ce qu'il comporte en outre :

une section engagee (37) et une section engageante (20) qui, lorsqu'elles sont engagees l'une avec l'autre, sont aptes a absorber un defaut d'alignement qui apparait sur une partie fixee ou l'arbre de sortie (4) et l'arbre d'entree (13) sont fixes,

la section engagee (37) etant situee sur l'un ou l'autre de l'element (36) d'attache de moteur et de l'element mene (11),

la section engageante (20) etant situee sur l'autre de l'element (36) d'attache de moteur et de l'element mene (11) et etant engagee avec la section engagee (37) de maniere a contenir une rotation du moteur (2) autour de l'axe de rotation de son arbre de sortie (4).

...

CLMDE

1. Ein Motorbefestigungsmechanismus zur Befestigung einer Abtriebswelle (4) eines Motors (2) und einer Antriebswelle (13) eines angetriebenen Elements (11) miteinander, umfassend:

einen Befestigungsteilbereich (6), der die Abtriebswelle (4) des Motors und die Antriebswelle (13) des angetriebenen Elements (11) in zueinander relativ unbeweglicher Weise befestigt;

ein Motoranschlusselement (36), das an dem Motor (2) angeschlossen ist; dadurch gekennzeichnet, dass es weiterhin umfasst:

einen im Eingriff stehenden Teilbereich (37) und einen Eingriffsteilbereich (20), die bei einem Eingriff miteinander dazu geeignet sind, die Fehltausrichtung aufzufangen, die auf einem befestigten Abschnitt auftritt, wo die Abtriebswelle (4) und die Antriebswelle (13) befestigt sind,

wobei der in Eingriff stehende Teilbereich (37) sowohl auf dem Motoranschlusselement (36) als auch auf dem angetriebenen Element (11) vorgesehen ist,

wobei der Eingriffsteilbereich (20) auf dem anderen der Motoranschlusselemente (36) und dem angetriebenen Element (11) vorgesehen ist und mit dem im Eingriff stehendem Teilbereich (37) in Eingriff steht, so dass die Drehung des Motors (2) um die Rotationsachse seiner Abtriebswelle (4) beschränkt ist.

...

20070314	EPB241	Request for examination 2006092820070314
20070314	EPB430	Unexamined document without grant, (first publication) 2007031420070314
20070314	EPB840	Designated contracting states AT BE BG CH CY CZ DE DK EE ES FI FR GB GR HU IE IS IT LI LT LU LV MC NL PL PT RO SE SI SK TR EP 1762772 A1 2007031420070314
20070314	EPB844EP	Extension of the European patent to AL BA HR MK YU20070314
20070808	EPB242	Dispatch of the first examination report 2007070620070809
20071121	EPB840N	Payment of designation fees DE FR GB IT20071121
20071121	EPB844EPN	Payment of extension fees20071121
20080326	EPB452EP	Intention to grant 2008022720080326
20080813	EPB450	Document with grant, second publication 2008081320080813
20080813	EPB840	Designated contracting states DE FR GB IT EP 1762772 B1 2008081320080813
20080813	EPB880	Publication of search report (A3 publication) 2007031420080813
20090722	EPB078EP	No opposition filed 2009051420090722

DISPLAY BRIEF (Derwent format)

AN 2005:65026 EPFULL EDP 20060223 ED 20060223 UP 20090218
DUPD 20090218 DUPW 200908
TIEN Wheelbarrow.
TIFR Brouette.
TIDE Schubkarre.
IN Lim, Fong Kan, Lot 39, Rawang Industrial Estate, 16 1/2 Miles, Jalan
Ipoh, 48000 Rawang Selangor, MY
PA Prestar Manufacturing SDN BHD, Lot 39, Rawang Industrial Estate 16 1/2
Miles, Jalan Ipoh, 48000 Rawang, Selangor, MY
PAN 7106830
AG Dehmel, Albrecht, et al, Dehmel & Bettenhausen Patentanwaelte,
Herzogspitalstrasse 11, 80331 Muenchen, DE
AGN 77812
DT Patent
LAF English
LA English
LAP English
TL German; English; French
PIT EPA2 Application published without search report
PI EP-----1625990 A2 20060215
EP-----1625990 A3 20080206
AI 2005EP-000466008 A 20050810
PRAI 2004MY-000003274 A 20040812
IPCI B62B-0001-22 [I,A]; B62B-0001-24 [I,A]
B62B-0001-00 [I,C*]; B62B-0001-00 [I,C*]

ABEN

The present invention is an improved wheelbarrow with a releasable container connected to a releasable locking system for easy pouring and requiring small leverage to lift the container. The improved wheelbarrow comprising a lever mounted directly on the handle part of the wheelbarrow support frame for easily release the container during removing load process. The lever is joined to a pivotal hook which is mounted on the body of the support frame by a cable. The container includes a fixture on the lower part rear end of the container. This is to secure the container to the releasable locking system when in loading or moving position. With the grasping of the lever, a tension force is formed and thus pulled the pivotal hook backward away from the hooked position. This releases the container from its secured position and can be easily lifted for emptying purposes.

(image, imgaf001.tif, drawing)

MCLMEN

A wheelbarrow with releasable container comprising:

- a support frame;
- a pair of handle connected to said support frame of said wheelbarrow;
- a container pivotably mounted to said support frame at the lower part front end of said container;
- a fixture mounted at the rear end of said container;
- a pivotable hook mounted at the body of said handle; and

a lever disposed at the rear end of said handle, whereby said fixture, pivotable hook and said lever collectively forming a releasable locking system and said pivotable hook is responsive to the lever to engage with said fixture when said container is in attached position and disengage with said fixture when said container is in released position.

DISPLAY STD (STN format)

AN 2007:56845 EPFULL EDP 20080227 ED 20090114 UP 20090114
DUPD 20090114 DUPW 200903
TIEN PIEZOACTUATOR WITH A CASING.
TIFR PIEZO-ACTIONNEUR COMPORTANT UN GAINAGE.
TIDE PIEZOAKTOR MIT EINER UMMANTELUNG.
IN SCHAICH, Udo, Keltenweg 57, 70378 Stuttgart, DE;
KIONTKE, Martin, Schubartstrasse 3a, 70825 Korntal-Muenchingen, DE;
KOERKEMEYER, Jens, Alexandrinenplatz 1, 71686 Remseck, DE
PA Robert Bosch GmbH, Postfach 30 02 20, 70442 Stuttgart, DE
PAN 8085980
DT Patent
LAF German
LA German
LAP German
TL German; English; French
PIT EPA2 Application published without search report
PI EP 2013923 A2 20090114
WO 2007122153 20071101
DS AT BE BG CH CY CZ DE DK EE ES FI FR GB GR HU IE IS IT LI LT LU LV MC MT
NL PL PT RO SE SI SK TR
EXTENSION STATES: AL BA HR MK RS
AI EP 2007-728229 A 20070418
WO 2007-EP53767 A 20070418
PRAI DE 2006-102006019047 A 20060425
IPCI H01L0041-053 [I,A]; H01L0041-083 [I,A]
H01L0041-00 [I,C*]; H01L0041-083 [I,C*]

In North America

CAS
STN North America
P.O. Box 3012
Columbus, Ohio 43210-0012 U.S.A.

CAS Customer Center:
Phone: 800-753-4227 (North America)
614-447-3700 (worldwide)
Fax: 614-447-3751
E-mail: help@cas.org
Internet: www.cas.org

In Europe

FIZ Karlsruhe
STN Europe
P.O. Box 2465
76012 Karlsruhe
Germany
Phone: +49-7247-808-555
Fax: +49-7247-808-259
E-mail: helpdesk@fiz-karlsruhe.de
Internet: www.stn-international.com

In Japan

JAICI (Japan Association for
International Chemical Information)
STN Japan
Nakai Building
6-25-4 Honkomagome, Bunkyo-ku
Tokyo 113-0021, Japan
Phone: +81-3-5978-3601 (Technical Service)
+81-3-5978-3621 (Customer Service)
Fax: +81-3-5978-3600
E-mail: support@jaici.or.jp (Technical Service)
customer@jaici.or.jp (Customer Service)
Internet: www.jaici.or.jp