

FRFULL (French Patents Full Text)

Subject Coverage	All patent-relevant areas of science and technology, i.e., all classes of the International Patent Classification.					
File Type	Full Text					
Features	Thesaurus	International Patent Classification (/IPC), European Patent Classification (/EPC and /ICO)				
	Alerts (SDIs)	Weekly or monthly (weekly is the default)				
	CAS Registry Numbers [®]	<input type="checkbox"/>	Page Images	<input type="checkbox"/>	STN AnaVist	<input type="checkbox"/>
	Keep & Share	<input checked="" type="checkbox"/>	SLART	<input checked="" type="checkbox"/>	STN Easy	<input checked="" type="checkbox"/>
	Learning Database	<input type="checkbox"/>	Structures	<input type="checkbox"/>	STN Viewer	<input checked="" type="checkbox"/>
Record Content	<ul style="list-style-type: none"> • Full text of patent applications, patent specifications, and utility models published in France. • Text has been created by Optical Character Recognition (OCR) software. Therefore, characters may be misinterpreted, or portions of the text may be incomplete. A small percentage of records are absent because they failed to scan. • Database records comprise all documents published for one application. • Records of the database contain bibliographic data, titles, and full text of description and claims in English and French for all publication stages. Abstract, description, and claims in English are machine translations. • Patents of invention (FRA) are available from 1902 to 1968. Documents for the whole period have abstracts, descriptions, and claims in English and French. • Applications for patents of invention (FRA1) are available since 1969. Documents from 1969 onwards have abstracts, descriptions, and claims in English and French. • Patents of invention (FRB1) are available since 1973. Abstracts in English are available from 1973 onwards; descriptions and claims in English and French are available from 1989 onwards. • Clipped images (mostly front-page images) from 1975 onwards are also included, when available. • Legal status data, family and citation display formats from the INPADODB database are available. 					
File Size	<ul style="list-style-type: none"> • More than 2.3 million records (04/12) • More than 300,000 images (04/12) 					
Coverage	1902-present					
Updates	Weekly					
Language	English, French					
Database Producer	LexisNexis Univentio BV Galileiweg 8 2333 BE Leiden The Netherlands Phone: (+31) 88-6390000 E-mail: customersupport@univentio.com Copyright Holder					

Database Supplier FIZ Karlsruhe
STN Europe
P.O. Box 2465
76012 Karlsruhe
Germany
Phone:+49 7247 808-555
Fax: +49 7247 808-259
E-mail: helpdesk@fiz-karlsruhe.de

Sources French Patents Full Text Documents

- User Aids**
- Online Helps (HELP DIRECTORY lists all help messages available)
 - STNGUIDE
-

- Clusters**
- AEROTECH
 - ALLBIB
 - AUTHORS
 - CORPSOURCE
 - ENGINEERING
 - FULLTEXT
 - HPATENTS
 - PATENTS
 - PNTTEXT
- [STN Database Clusters](#) information (PDF)
-

Pricing See the [STN Price List](#) or enter HELP COST at an arrow prompt.

Search and Display Field Codes

If multiple search terms are linked with and AND-operator, all terms are searched in the complete database record, i.e. in all publications referring to one application. For a search in a specific publication of the record, connect the search term and the patent kind code with the (L)-proximity operator, e.g. S FILTRER DES SIGNAUX/AB, TI, CLM (L) FRA1/PK limits the search to French applications FRA1.

Fields that allow left truncation are indicated by an asterisk (*).

General Search Fields

Search Field Name	Search Code	Search Examples	Display Codes
Basic Index* (contains single words from the titles (TIEN, TIFR), abstracts (ABEN, ABFR), detailed description (DETDEN, DETDFR), claims (CLM), and main claims (MCLM) fields)	None or /BI	S TRANSISTOR AND ELECTRODE S SENSOR FOR DETERMINER S TRAITEMENT? ULTERIEUR S ?TRANSFER	TIEN, TIFR, ABEN, ABFR, DETDEN, DETDFR, CLMEN, CLMFR, MCLMEN, MCLMFR
Abstract* (in English and French)	/AB	S FILTRER DES SIGNAUX/AB S PROCEDE SELON/AB	ABEN, ABFR
Accession Number	/AN	S 2427770/AN	AN
Application Country (WIPO code and text)	/AC	S FR/AC	AI
Application Date (1)	/AD	S AD=JAN 2003	AI
Application Number (2)	/AP (or /APPS)	S FR2000-10010/AP S 2000FR-0010010/APPS	AI
Application Year (1)	/AY	S AY>=2000	AY
Claims* (in English and French)	/CLM	S DERIVATION/CLM	CLMEN, CLMFR
Document Type (code and text)	/DT (or /TC)	S U/DT S UTILITY MODEL/DT	DT
Entry Date (1)	/ED	S ED=MAR 2004	ED
Entry Week (1)	/EW	S EW>200800	EW
European Patent Classification (3)	/EPC (or /ECLA)	S A01B0033-08B2/EPC	EPC
Field Availability	/FA	S ABEN/FA	FA
Graphic Image Size (1)	/GIS	S 200-300/GIS	GIS
ICO (in computer only) (3)	/ICO	S L29C0065:16+B10/ICO	ICO
ICO Keyword Terms	/ICO.KW	S A4/ICO.KW	ICO
IdT (Indeling der Techniek)	/IDT	S B42D15/00C/IDT	IDT
International Patent Classification (ICM, ICS, IPCI, IPCR) (3)	/IPC	S H05K0007-20/IPC	ICM, ICS, IPCI, IPCR
International Patent Classification (ICM, ICS)	/IC	S A24B/IC	ICM, ICS
Inventor (current and old)	/IN (or /AU)	S MANAUT DANIEL/IN S MANCEAUX?/IN	IN
IPC Main Group (range searchable (1,4))	/MGR	S 10-20/MGR(S)C07C/IC	ICM, ICS
IPC Subgroup (range searchable) (1,4)	/SGR	S C01B/ICM(S)100-2000/SGR	ICM, ICS
IPC, Action Date (1)	/IPC.ACD	S 20051008/IPC.ACD	IPC.TAB
IPC, Initial	/IPCI	S B21B0001/IPCI	IPCI
IPC, Keyword Terms	/IPC.KW	S INITIAL/IPC.KW	IPC.TAB
IPC, Main	/ICM	S A01N001/ICM	ICM
IPC, Reclassified	/IPCR	S B21B0001/IPCR	IPCR
IPC, Secondary	/ICS	S A01B001-16/ICS	ICS
IPC, Version	/IPC.VER	S 7/IPC.VER	IPC.TAB
Language (ISO code and text)	/LA	S FR/LA S FRENCH/LA	LA
Language, Filing (ISO code and text)	/LAF	S FR/LAF	LAF

Search and Display Field Codes (cont'd)

Search Field Name	Search Code	Search Examples	Display Codes
Main Claim* (in English and French)	/MCLM	S ?FRACTURE?/MCLM	MCLMEN, MCLMFR
Number of Claims (1)	/CLMN	S 5-7/CLMN	CLMN
Number of Paragraphs in DETD (Detailed Description) (1)	/DETN	S DETN<10	DETN
Patent Applicant/Patentee (5)	/PA (or /CS)	S BASF AG/PA	PA
Patent Applicant/Patentee Country (WIPO code and text)	/PACNY	S DE/PACNY	PA, PACNY
Patent Country (WIPO code and text)	/PC	S FRANCE/PC	PI
Patent Information Publication Type	/PIT	S FRA1 APPLICATION, FIRST PUBLICATION/PIT	PIT
Patent Kind Code	/PK	S FRA2/PK	PI
Patent Number (2)	/PN (or /PATS)	S FR 2929171/PN	PI, PATS
Patent Number Kind Code	/PNK	S FR2120002 A1/PNK	PI, PNK
Priority Country (WIPO code and text)	/PRC	S AU/PRC	PRAI
Priority Date (1)	/PRD	S AUSTRALIA/PRC S PRD=APRIL, 2 2003	PRAI
Priority Kind Code	/PRK	S DE/APRK	PRAI
Priority Number (2)	/PRN	S DE2000-10023591/PRN	PRAI
Priority Type	/PRT	S NATIONAL APPLICATION/PRT	not displayed
Priority Year (1)	/PRY	S 1993/PRY	PRAI
Priority Year, First (1)	/PRYF	S 1993-1994/PRYF	PRAI, PRYF
Publication Date (1)	/PD	S PD=JAN-FEB 2003	PI
Publication Year (1)	/PY	S PY>2003 AND L1	PI
Title	/TI	S FLUID###/TI	TIEN, TIFR
Update Date (1)	/UP	S UP=APR 2004	UP
Update Week (1)	/UW	S UW>200400	UW

(1) Numeric search field that may be searched using numeric operators or ranges.

(2) By default, patent numbers, application and priority numbers are displayed in STN Format. To display them in Derwent format, enter SET PATENT DERWENT at an arrow prompt. To reset display to STN Format, enter SET PATENT STN.

(3) An online thesaurus is available in this field.

(4) Only valid for IPC version 1-7.

(5) Search with implied (S) proximity is available in this field.

International Patent Classification (IPC) Thesaurus

The classifications, validity and catchwords for the main headings and subheadings from the current (8th) edition of the WIPO International Patent Classification (IPC) manual are available. The classifications from the previous editions (1-7) are also available as separate thesauri. To EXPAND and SEARCH in the thesauri for editions 1-7, use the field code followed by the edition number, e. g., /IPC2, for the 2nd edition. Catchwords are included only in the thesauri for the 8th, 7th, 6th, and 5th editions.

Code	Content	Examples
ADVANCED (ADV)	Advanced Codes for the Core Level IPC Code	E A61K0006-02+ADVANCED/IPC
ALL	All Associated Terms (BT, SELF, NT, RT)	E C01C003-00+ALL/IPC
BRO (MAN)	Complete Class	E C01C+BRO/IPC
BT	Broader Term (BT, SELF)	E C01F001-00+BT/IPC
CORE (COR)	Core Codes for the Advanced Level IPC Code	E G08C0019-22+CORE/IPC
ED	Complete title of the SELF term and IPC manual edition	E C01F001-00+ED/IPC
HIE	Hierarchy Term (Broader and Narrower Term) (BT, SELF, NT)	E C01B003-00+HIE/IPC

International Patent Classification (/IPC) Thesaurus (cont'd)

Code	Content	Examples
INDEX KT NEXT NT PREV RT (SIB) TI	Complete title of the SELF term Keyword Term (catchwords) (SELF, KT) Next Classification Narrower Terms (SELF, NT) Previous Classification Related Terms (SELF, RT) Complete Title of the SELF Term and Broader Terms (BT, SELF)	E C01F001-00+INDEX/IPC E CYANOGEN+KT/IPC E C01C001-00+NEXT5/IPC E C01C+NT/IPC E C01C001-12+PREV10/IPC E C01C003-20+RT/IPC E C01F001-00+TI/IPC

ECLA (/EPC) and ICO Thesauri

These thesauri are available in the /EPC search field (for ECLA codes) and /ICO search field (for 'in-computer-only' codes). All relationship codes can be used with both the EXPAND and SEARCH commands.

Relationship Code	Content	Search Examples
ALL AUTO (1) BT CODE	All usually required terms (BT, SELF, CODE, DEF) Automatic relationship (BT, SELF, CODE, DEF) Broader terms (BT, SELF) Classification Code (SELF, CODE)	E C12M0001-34H2+ALL/EPC E G01J003-443+AUTO/EPC E G01J0003-443+BT/EPC E SCRAPER BIASING MEANS+CODE/EPC
DEF HIE	Definition (SELF, DEF) Hierarchy terms (all broader and narrower terms) (BT, SELF, DEF, NT)	E B65G0045-16+DEF/EPC E A01B0001+HIE/EPC
KT MAX NEXT NEXT(n) NT PREV PREV(n) TI	Keyword terms (SELF, KT) All associated terms Next classification within the same class (SELF, NEXT) Next n classification within the same class Narrower terms Previous Code within the same class (SELF, PREV) Previous n classifications within the same class Complete Title of the SELF Term and Broader Terms (BT, SELF)	E LASER+KT/EPC E G01J0003-44B+MAX/EPC E A01B0001-24+NEXT/EPC E A01B0001-24+NEXT3/EPC E G05B0001-04+NT/EPC E G05B0019-418N1+PREV/EPC E G05B0019-418N1+PREV2/EPC E G05B0001-03+TI/EPC

(1) Automatic Relationship is SET OFF. In case of SET REL ON the result of EXPAND or SEARCH without any relationship code is the same as described for AUTO.

DISPLAY and PRINT Formats

Any combination of formats may be used to display or print answers. Multiple codes must be separated by spaces or commas, e.g., D L1 1-5 TI PI. The fields are displayed or printed in the order requested.

The information of the latest publication is displayed by default. To display the content for all levels of the record you can combine all display fields and formats with the qualifier .M except FA, FAM, CFAM, LS, LS2, SCAN, and TRIAL.

For displaying a particular publication of a database record, you can simply add for certain display field the kind code to the appropriate display format, e.g. ALL.A1. Fields that allow this are indicated by a number (2).

Hit-term highlighting is available for most searchable fields. Highlighting must be ON during SEARCH to use the HIT, KWIC, and OCC formats.

Format	Content	Examples
ABEN	Abstract in English	D ABEN
ABFR	Abstract in French	D ABFR
AI (AP) (1)	Application Information	D AI
AN	Accession Number	D AN
CLM (2)	Claims (CLMFR, CLMEN)	D CLM
CLMEN (2)	Claims in English	D CLMEN
CLMFR (2)	Claims in French	D CLMFR
CLMN (2, 3)	Number of Claims	D CLMN
DETD (2)	Detailed Descriptions (DETDFR, DETEN)	D DETD
DETDEN (2)	Detailed Description in English	D DETDEN
DETDFR (2)	Detailed Description in French	D DETDFR
DETN (2, 3)	Number of Paragraphs in DETD	D DETN
DT (TC)	Document Type	D DT
ED	Entry Date	D ED
EPC	European Patent Classification	D EPC
EW	Entry Week	D EW
FA	Field Availability	D FA
GI	Graphic Image	D GI
GIS (3)	Graphic Image	D GIS
GIT (3)	Graphic Image Type	D GIT
IC	IPC (format contains ICM, ICS)	D IC
ICM	IPC, Main	D ICM
ICO (3)	ICO Classification	D ICO
ICS	IPC, Secondary	D ICS
IDT (3)	IDT Classification	D IDT
IN (AU)	Inventor	D IN
IPC	IPC (ICM, ICS, ICA, ICI, IPCI, IPCR)	D IPC
IPCI	IPC, Initial	D IPCI
IPCR	IPC, Reclassified	D IPCR
LA	Language	D LA
LAF	Language of Filing	D LAF
MCLM (2)	Main Claims (MCLMFR, MCLMEN)	D MCLM
MCLMEN (2)	Main Claim in English	D MCLMEN
MCLMFR (2)	Main Claim in French	D MCLMFR
PA (CS)	Patent Applicant/Patentee	D PA
PACNY	Patent Applicant/Patentee Country	D PACNY
PI (PN, PATS) (1)	Patent Information	D PI
PIT	Patent Information Publication Type	D PIT
PRAI (PRN) (1, 5)	Priority Information	D PRAI
PRAO (PRNO) (3)	Priority Number Original Format	D PRAO
PRYF	Priority Year, First	D PRYF
TI	Titles (TIEN, TIFR)	D TI
TIEN	Title in English	D TIEN
TIFR	Title in French	D TIFR
UP	Update Date	D UP
UW	Update Week	D UW

DISPLAY and PRINT Formats (cont'd)

Format	Content	Examples
AB (ABS) ALL (DALL) (1,2)	ABEN, ABFR AN, ED, EW, UP, UW, TI, IN, PA, PACNY, LA, LAF, DT, PIT, PI, AI, PRAI, IPC, EPC, ICO, IDT, AB, DETDFR, CLMFR, DETDEN, CLMEN	D AB D ALL
ALLG (1,2) IALL (1,2) IALLFR (1,2) IALLG (1) APPS (1)	ALL, plus graphic Image ALL, indented with text labels ALL, Indented with text labels, French terminology IALL, plus graphic Image AI, PRAI	D ALLG D IALL D IALLFR D IALLG D APPS
BIB (1,2) IBIB (1,2) IBIBFR (1,2) BRIEF(1, 2)	AN, ED, TI, IN, PA, LA, LAF, DT, PIT, PI, AI, PRAI BIB, indented with text labels BIB, indented with text labels, French terminology AN, ED, EW, TI, IN, PA, LAF, DT, PIT, PI, AI, PRAI, IPC, EPC, ICO, IDT, AB, MCLM	D BIB D IBIB D IBIBFR D BRIEF
BRIEFG (1) IBRIEF (1,2) IBRIEFFR (1,2) IBRIEFG (1) FAM (1,2) CFAM (1,2) IND IPC IPC.TAB LS (2) LS2 (2) MAX (ALL.M) (1)	BRIEF, plus graphic Image BRIEF, indented with text labels BRIEF, indented with text labels, French terminology IBRIEF, indented plus graphic Image AN, table of patent family information (from INPADOCDB) AN, condensed family format (from INPADOCDB) IPC (ICM, ICS, IPCI, IPCR), EPC, ICO, IDT International Patent Classification (ICM, ICS, IPCI, IPCR) IPC, IPC.KW, IPC.ACD, IPC.VER, in tabular version Legal Status (from INPADOCDB) Legal Status (from INPADOCDB), detailed version with display headers AN, ED, EW, UP, TI, IN, PA, PACNY, LA, LAF, DT, PIT, PI, AI, PRAI, IPC, EPC, ICO, IDT, AB, DETDFR, CLMFR, DETDEN, CLMEN for all levels of publication	D BRIEFG D IBRIEF D IBRIEFFR D IBRIEFG D FAM D CFAM D IND D IPC D IPC.TAB D LS D LS2 D MAX
MAXG (ALLG.M) (1) IMAX (IALL.M) (1) IMAXFR IMAXG (IALLG.M) (1) RE (2) SCAN (4) STD (1,2)	MAX, plus graphic Image MAX, indented with text labels MAX, Indented with text labels, French terminology IMAX, plus graphic Image Citations of patent and non-patent literature (from INPADOCDB) TI (random display without answer numbers) AN, ED, TI, IN, PA, LA, LAF, DT, PIT, PI, AI, PRAI, IPC, EPC, ICO, IDT (STD is default)	D MAXG D IMAX D IMAXFR D IMAXG D RE D SCAN D STD
STDG (1) ISTD (1,2) ISTDFR (1,2) ISTDG (1) TRIAL (TRI, SAMPLE, SAM, FREE) TX (2)	STD plus graphic Image STD, indented with text labels STD, indented with text labels, French terminology ISTD, plus graphic Image TI, FA, DETN, CLMN, GIS, GIT DETDFR, CLMFR, DETDEN, CLMEN	D STDG D ISTD D ISTDFR D ISTDG D TRIAL D TX
HIT KWIC OCC	Hit term(s) and field(s) Up to 50 words before and after hit term(s) (Keyword-In-Context) Number of occurrences of hit term(s) and field(s) in which they occur	D HIT D KWIC D OCC

- (1) By default, patent numbers, application and priority numbers are displayed in STN Format. To display them in Derwent format, enter SET PATENT DERWENT at an arrow prompt. To reset display to STN Format, enter SET PATENT STN.
- (2) You can combine this display field with the qualifier .PK (Patent Kind Code) to display the content for a certain publication level of a record, e.g. STD.A1.
- (3) Custom display only.
- (4) SCAN must be specified on the command line, i.e., D SCAN or DISPLAY SCAN.
- (5) If priority information is not available for a certain document, this information is taken from the application information of this document and marked with an asterisk (*).

SELECT, ANALYZE, and SORT Fields

The SELECT command is used to create E-numbers containing terms taken from the specified field in an answer set.

The ANALYZE command is used to create an L-number containing terms taken from the specified field in an answer set.

The SORT command is used to rearrange the search results in either alphabetic or numeric order of the specified field(s).

You can combine all fields except FA with the qualifier .M to SELECT/ANALYZE the content of all publication levels.

Field Name	Field Code	ANALYZE/ SELECT (1)	SORT
Abstract (English and French)	AB	Y	N
Abstract in English	ABEN	Y (2)	N
Abstract in French	ABFR	Y (2)	N
Accession Number	AN	Y	Y
Application Country	AC	Y	N
Application Date	AD	Y	N
Application Information	AI (AP, APPS)	Y (3)	N
Application Year	AY	Y	N
Claims (English and French)	CLM	Y	N
Claims in English	CLMEN	Y (4)	N
Claims in French	CLMFR	Y (4)	N
Designated State	DS	Y	N
Detailed Description (English and French)	DETD	Y (5)	N
Detailed Description in English	DETDEN	Y (5)	N
Detailed Description in French	DETDFR	Y (5)	N
Document Type	DT (TC)	Y	Y
Entry Date	ED	Y	Y
Entry Week	EW	Y	Y
European Patent Classification	EPC	Y	N
Field Availability	FA	Y	N
Graphic Image Size	GIS	Y	Y
International Patent Classification	IC	Y	N
Inventor	IN (AU)	Y	Y
ICO Classification	ICO	Y	Y
IdT Classification	IDT	Y	Y
IPC (ICM, ICS, ICA, ICI, IPCI, IPCR)	IPC	Y	Y
IPC, Advanced Level Symbols	IPC.A	Y (6)	N
IPC, Advanced Level Symbols for Invention	IPC.AI	Y (6)	N
IPC, Core Level Symbols	IPC.C	Y (6)	N
IPC, Core Level Symbols for Invention	IPC.CI	Y (6)	N
IPC, Initial	IPCI	Y (6)	Y
IPC, Main	ICM	Y	Y
IPC, Reclassified	IPCR	Y (6)	Y
IPC, Secondary	ICS	Y	Y
Language	LA	Y	Y
Language of Filing	LAF	Y	Y
Main Claim (English and French)	MCLM	Y	N
Main Claim in English	MCLMEN	Y (7)	N
Main Claim in French	MCLMFR	Y (7)	N
Number of Claims	CLMN	Y	N
Number of Paragraphs in DETD	DETN	Y	N
Occurrence Count of Hit Terms	OCC	N	Y
Patent Applicant/Patentee Country	PACNY	Y	Y
Patent Applicant/Patentee	PA (CS)	Y	Y
Patent Country	PC	Y	Y
Patent Information Publication Type	PIT	Y	Y

SELECT, ANALYZE, and SORT Fields (cont'd)

Field Name	Field Code	ANALYZE/ SELECT (1)	SORT
Patent Kind Code	PK	Y	Y
Patent Number	PI (PN, PATS)	Y (3)	Y
Pre-IPC8 Symbols from the ICM and first IPC8 values from 2006-present	IPC.F	Y (6)	N
Priority Country	PRC	Y	Y
Priority Date	PRD	Y	Y
Priority Number	PRN (PRAI)	Y (3)	Y
Priority Number, Original Format	PRNO	Y	Y
Priority Year	PRY	Y	Y
Priority Year, First	PRYF	Y	Y
Publication Date	PD	Y	Y
Publication Year	PY	Y	Y
Subclass	SCL	Y (8)	N
Subclass Group	SCG	Y (8)	N
Subclass Group Main	SCGM	Y (9)	N
Subclass Main	SCLM	Y (9)	N
Title	TI	Y (10) (default)	Y
Title in English	TIEN	Y (11)	Y
Title in French	TIFR	Y (11)	Y
Update Date	UP	Y	Y
Update Week	UW	Y	Y

- (1) HIT may be used to restrict terms extracted to terms that match the search expression used to create the answer set, e.g., SEL HIT TI.
- (2) Appends /AB to the terms created by SELECT.
- (3) SELECTed, ANALYZed, and SORTed application, priority, and patent numbers are in the format set by the MESSENGER SET PATENT command, either Derwent or STN.
- (4) Appends /CLM to the terms created by SELECT.
- (5) Appends /BI to the terms created by SELECT.
- (6) Appends /IPC to the terms created by SELECT.
- (7) Appends /MCLM to the terms created by SELECT.
- (8) Appends /IC to the terms created by SELECT.
- (9) Appends /ICM to the terms created by SELECT.
- (10) Selects TIEN and TIFR with /TI appended to the terms created by SELECT.
- (11) Appends /TI to the terms created by SELECT.

FRFULL

Sample Records**DISPLAY BIB.M**

AN 2865532 FRFULL ED 20050811 EW 200530
UP 20100117

TIEN Light weight field howitzer - includes a barrel which is supported by a
cradle constructed from hollow members and which is pivotally mounted
about a trunnion bearing secured to a chassis

TIFR PERFECTIONNEMENT AUX OBUSIERS DE CAMPAGNE
IN SEARLE HAROLD LESLIE; EAGLESTONE DAVID ANDREW; BONE JAMES
PA VICKERS SHIPBUILDING AND ENGINEERING LIMITED
PA.CNY GB
LAF French
LA French
DT Patent
PIT FRA1 APPLICATION FOR PATENT OF INVENTION, (FIRST PUBL.) (FROM 2,000,000)
PI FR 2865532 A1 20050729
AI FR 1990-7815 A 19900620
PRAI GB 1988-29192 A 19881214

AN 2865532 FRFULL ED 20100110
UP 20100110

TIEN IMPROVEMENT WITH THE FIELD HOWITZERS
TIFR PERFECTIONNEMENT AUX OBUSIERS DE CAMPAGNE
IN SEARLE HAROLD LESLIE; EAGLESTONE DAVID ANDREW; BONE JAMES
PA VICKERS SHIPBUILDING AND ENGINEERING LIMITED
PA.CNY GB
LAF French
LA French
DT Patent
PIT FRB1 PATENT OF INVENTION (SECOND PUBLICATION) (FROM 2,000,000)
PI FR 2865532 B1 20070810
AI FR 1990-7815 A 19900620
PRAI GB 1988-29192 A 19881214

DISPLAY IBRIEFFR

NUMERO D. ACCESSION: 2865532 FRFULL ED 20100110
TITRE (ANGLAIS): IMPROVEMENT WITH THE FIELD HOWITZERS
TITRE (FRANCAIS): PERFECTIONNEMENT AUX OBUSIERS DE CAMPAGNE
INVENTEUR(S): SEARLE HAROLD LESLIE; EAGLESTONE DAVID ANDREW; BONE
JAMES
DEPOSANT(S): VICKERS SHIPBUILDING AND ENGINEERING LIMITED
GB
LANGUE DEPOT: Francaise
LANGUE PUBL.: Francaise
NATURE D. PUBL.: Brevet
INFORM. PUBLICAT.:

	NUMERO	TYPE	DATE

	FR 2865532	B1	20070810
INF. APPLICATION:	FR 1990-7815	A	19900620
INFORM. PRIORITE:	GB 1988-29192	A	19881214
IPC ORIGINAL (ADV):	F41F0001-00	[I,A]	
IPC ORIGINAL (CORE):	F41F0001-00	[I,C*]	
IPC RECLASSIF. (ADV):	F41A0023-30	[I,A]; F41A0025-16	[I,A];
	F41A0027-08	[I,A]; F41A0027-24	[I,A];
	F41A0027-30	[I,A]	
IPC RECLASSIF. (CORE):	F41A0023-00	[I,C*]; F41A0025-00	[I,C*];

F41A0027-00 [I,C*]; F41A0023-30; F41A0025-16;
F41A0027-08; F41A0027-24; F41A0027-30

REVENDEICATION PRINCIPALE (FRANCAIS):

1.- Obusier de campagne qui comprend : (i) un tube d'obusier (101) ; (ii) un berceau (119A, 125, 126) supportant le tube et comportant une extremite arriere ; (iii) un chassis (117) ; et (iv) une structure support de tourillon (124) fixee sur le chassis (117) et comprenant un palier de tourillon (113) autour duquel l'extremite arriere du'berceau est montee a pivotement, ledit palier de tourillon se trouvant sur l'axe (101A) du tube (101) et etant place au-dela de la limite du recul maxi- mal du tube.

REVENDEICATION PRINCIPALE (ANGLAIS):

1. - Field howitzer which includes/understands: (I) a tube of howitzer (101); (II) a cradle (119A, 125,126) supporting the tube and comprising a back end; (III) a frame (117); and (iv) a structure support of pivot (124) fixed on the frame (117) and including/understanding a stage of pivot (113) around whose the end postpones du' cradle is assembled to swivelling, the aforementioned stage of being pivot on the axis (101A) tube (101) and being placed beyond the limit of the maximum retreat evil of the tube.

DISPLAY MAXG

AN 2929529 FRFULL ED 20091022 EW 200941
UP 20091110

TIEN BODY OF FIXING FOR A TE OF SPORT

TIFR ORGANE DE FIXATION POUR UN TE DE SPORT

IN YANG CHUI-CHING

PA CHUANG YII ENTERPRISE CO., LTD

PA.CNY TW

LAF French

DT Utility Model

PIT FRA3 APPLICATION FOR CERTIFICATE OF UTILITY, (FIRST PUBL.) (FROM
2,000,000)

PI FR 2929529U A3 20091009

AI FR 2008-52289 A 20080407

PRAI FR 2008-52289 A 20080407 *

IPCI A63B0071-00 [I,A]

A63B0071-00 [I,C*]

ABEN A body of fixing for a t-piece of sport presents a base (10) and a sleeve (20). The base (10) is out of plastic and present a tubular mounting (13). The sleeve (20) is metal and is assembled around the tubular mounting (13) of the base (10). The metal sleeve (20) protects the body from fixing with respect to wear by an elastic device (30) of the t-piece of sport. Consequently, the body of fixing with the base (10) out of plastic and the metal sleeve (20) can be carried out easily, is durable, present of low costs and is particularly suitable for the t-piece of sport.

ABFR Un organe de fixation pour un te de sport presente une base (10) et un manchon (20). La base (10) est en matiere plastique et presente une monture tubulaire (13). Le manchon (20) est metallique et est monte autour de la monture tubulaire (13) de la base (10). Le manchon metallique (20) protege l'organe de fixation vis-a-vis de l'usure par un dispositif elastique (30) du te de sport. Par consequent, l'organe de fixation avec la base (10) en matiere plastique et le manchon metallique (20) peut etre realise facilement, est durable, presente de faibles

couts et est particulièrement appropriée pour le te de sport.

DETDFR ORGANE DE FIXATION POUR UN TE DE SPORT La présente invention porte sur un organe de fixation, en particulier sur un organe de fixation pour un te de sport qui peut être réalisé facilement et qui est durable et de faible coût. Un te de sport classique comprend un organe de fixation, un dispositif élastique et une cible. L'organe de fixation peut être monté sur un mur, un plancher, un plafond, une barre transversale ou similaires. Le dispositif élastique est maintenu sur l'organe de fixation et présente une extrémité distale. La cible peut être une balle, telle qu'une balle de golf, une balle de base-bail, une balle de football, un punching bail ou similaires et est montée sur l'extrémité distale du dispositif élastique. Lorsque la cible est frappée, le dispositif élastique peut être plié puis revient par élasticité à un état initial pour amortir et absorber un impact et réduire l'impact qui est transmis à l'organe de fixation. Lorsque l'organe de fixation est métallique pour une durabilité améliorée, l'organe de fixation est lourd et est fabriqué à des coûts élevés. Lorsque l'organe de fixation est en matière plastique pour pouvoir être porté plus facilement et être fabriqué à des coûts inférieurs, l'emploi d'une matière plastique pour l'organe de fixation amène ce dernier à être facilement défaillant. De plus, l'impact à travers le dispositif élastique use l'organe de fixation en matière plastique facilement et amène l'organe de fixation en matière plastique à être facilement défaillant. Pour surmonter les inconvénients, la présente invention propose un organe de fixation pour un te de sport pour pallier ou diminuer les problèmes mentionnés ci-dessus. L'objectif principal de la présente invention porte sur un organe de fixation pour un te de sport qui a une base et un manchon. La base est en matière plastique et présente une monture tubulaire. Le manchon est métallique et est monté autour de la monture tubulaire de la base. Le manchon métallique protège l'organe de fixation vis-à-vis d'une usure par un dispositif élastique du te de sport. Par conséquent, l'organe de fixation avec la base en matière plastique et le manchon métallique peut être fabriqué facilement, il est durable, il est de faible coût et est particulièrement approprié pour le te de sport. La présente invention a donc pour objet un organe de fixation pour un te de sport, caractérisé par le fait qu'il comprend : - une base qui est en matière plastique et qui a un connecteur ayant une surface externe ; un siège qui est formé sur et fait saillie à partir de la surface externe du connecteur et qui a une surface externe ; et une monture tubulaire qui est formée sur et fait saillie à partir de la surface externe du siège et ayant un épaulement de montage qui est formé sur et fait saillie à partir de la surface externe du siège et ayant une extrémité distale ; et un col de montage qui est formé sur et fait saillie à partir de l'extrémité distale de l'épaulement de montage et qui a une extrémité distale ; et - un manchon qui est métallique, étant monté autour du col de montage de la base et ayant deux extrémités. Conformément à des caractéristiques particulières de la présente invention : - la monture tubulaire de la base peut avoir en outre une cavité qui est formée dans l'extrémité distale de l'épaulement de montage et correspondant au col de montage ; et un organe d'arrêt qui est plus grand que et qui est formé sur l'extrémité distale du col de montage ; et - l'une des extrémités du manchon peut être montée dans la cavité de la monture tubulaire et l'autre extrémité du manchon peut venir en butée contre l'organe d'arrêt de la monture tubulaire. D'autres objectifs, avantages et nouvelles caractéristiques de la présente invention ressortiront plus facilement à la lecture de la description détaillée suivante faite en liaison avec les dessins annexes. Sur ces dessins - la Figure 1 est une vue en perspective d'un organe de fixation

pour un te de sport conforme a la presente invention ; - la Figure 2 est une vue en perspective operationnelle de l'organe de fixation de la Figure 1 avec un manchon qui est represente en traits mixtes ; - la Figure 3 est une vue laterale en coupe partielle de l'organe de fixation de la Figure 1 ; et - la Figure 4 est une vue en perspective operationnelle de l'organe de fixation de la Figure 1, un dispositif elastique ayant une cible etant montee sur l'organe de fixation. Si l'on se refere a la Figure 1, on peut voir qu'un organe de fixation pour un te de sport conforme a la presente invention peut etre fixe a un plancher, un mur, un plafond, un support ou similaires et comprend une base et un manchon 20. La base 10 est en matiere plastique et presente un connecteur 11, un siege 12 et une monture tubulaire 13. Le connecteur 11 est fixe au plancher, au mur, au plafond, au support ou similaires et presente une surface externe. Le siege 12 est forme sur et fait saillie a partir de la surface externe du connecteur 11 et a une surface externe. Si l'on fait a nouveau reference aux Figures 2 et 3, on peut voir que la monture tubulaire 13 est formee sur et fait saillie a partir de la surface externe du siege 12, presente un epaulement de montage 131 et un col de montage 132 et peut presenter une cavite 133 et un organe d'arret 134. L'epaulement de montage 131 est forme sur et fait saillie a partir de la surface externe du siege 12 et presente une extremite distale. Le col de montage 132 est forme sur et fait saillie a partir de l'extremite distale de l'epaulement de montage 131 et presente une extremite distale. La cavite 133 est formee dans l'extremite distale de l'epaulement de montage 131 et correspond au col de montage 132. L'organe d'arret 134 est plus grand que et est forme sur l'extremite distale du col de montage 132. Le manchon 20 est metallique, est monte autour du col de montage 132 de la base 10 et a deux extremités. L'une des extremités peut etre montee dans la cavite 133 de la monture tubulaire 13 et l'autre extremite peut venir en butee contre l'organe d'arret 134 de la monture tubulaire 13. Si l'on fait encore reference a la Figure 4, on peut voir que l'organe de fixation pour un te de sport tel que decrit a les avantages suivants. Le te de sport comprend en outre un dispositif elastique 30 et une cible 40. Le dispositif elastique 30 est monte autour du manchon et fait saillie a partir de la monture tubulaire 13 de la base 10 de l'organe de fixation. La cible 40 est reliee au dispositif elastique 30. Par consequent, le manchon metallique 20 protege l'organe de fixation vis-a-vis de l'usure par le dispositif elastique 30 et la base en matiere plastique 10 peut amortir et absorber les chocs du te de sport alors que la cible 40 est frappee. Par consequent, l'organe de fixation avec la base en matiere plastique 10 et le manchon metallique 20 peut etre fabrique facilement, est durable et de faible cout et est particulierement approprie pour un te de sport. Meme si de nombreuses caracteristiques et avantages de la presente invention ont ete enonces dans la description precedente, conjointement avec des details de la structure et des caracteristiques de l'invention, la divulgation n'est qu'illustrative. Des changements peuvent etre apportés dans les details, notamment dans des questions de forme, de dimension et de disposition de pieces a l'interieur des principes de l'invention dans la pleine mesure indiquee par la signification generale large des termes dans lesquels les revendications annexees sont exprimees.

CLMFR 1 - Organe de fixation pour un te de sport, caracterise par le fait qu'il comprend : - une base (10) qui est en matiere plastique et qui a un connecteur (11) ayant une surface externe ; un siege (12) qui est forme sur et fait saillie a partir de la surface externe du connecteur (11) et qui a une surface externe ; et une monture tubulaire (13) qui est formee sur et fait saillie a partir de la surface externe du siege

(12) et ayant un epaulement de montage (131) qui est forme sur et fait saillie a partir de la surface externe du siege (12) et ayant une extremite distale ; et un col de montage (132) qui est forme sur et fait saillie a partir de l'extremite distale de l'epaulement de montage (131) et qui a une extremite distale ; et - un manchon (20) qui est metallique, etant monte autour du col de montage (132) de la base (10) et ayant deux extremités.

2 - Organe de fixation selon la revendication 1, caracterise par le fait que : - la monture tubulaire (13) de la base a en outre une cavite (133) qui est formee dans l'extremite distale de l'epaulement de montage (131) et correspondant au col de montage (132) ; et un organe d'arret (134) qui est plus grand que et qui est forme sur l'extremite distale du col de montage (132) ; et - l'une des extremités du manchon (20) est montee dans la cavite (133) de la monture tubulaire (13) et l'autre extremite du manchon (20) vient en butee contre l'organe d'arret (134) de la monture tubulaire (13).

DETDEN BODY OF FIXING FOR a TE OF SPORT the present invention relates to a body of fixing, in particular on a body of fixing for a t-piece of sport which can be carried out easily and which is durable and of low costs. A traditional t-piece of sport includes/understands a body of fixing, an elastic device and a target. The body of fixing can be gone up on a wall, a floor, a ceiling, a bar transverse or similar. The elastic device is maintained on the body of fixing and presents a distal end. The target can be a ball, such as a golf ball, a ball of base-lease, a ball of football, a punching lease or similar and is assembled on the distal end of the elastic device. When the target is struck, the elastic device can be folded then returns by elasticity in an initial state to deaden and absorb an impact and to reduce the impact which is transmitted to the body of fixing. When the body of fixing is metal for an improved durability, the body of fixing is heavy and is manufactured at high cost. When the body of fixing is out of plastic to be able to be carried more easily and to be manufactured at lower cost, use of a plastic for the body of pleasing fixing this last with being easily failing. Moreover, the impact through the elastic device easily uses the body of fixing out of plastic and brings the body of fixing out of plastic to being easily failing. To overcome the disadvantages, the present invention proposes a body of fixing for a t-piece of sport to mitigate or decrease the problems mentioned cidessus. The main aim of this invention relates to a body of fixing for a t-piece of sport which has a base and a sleeve. The base is out of plastic and present a tubular mounting. The sleeve is metal and is assembled around the tubular mounting of the base. The metal sleeve protects the body from fixing with respect to a wear by an elastic device of the t-piece of sport. Consequently, the body of fixing with the plastic base and the metal sleeve can be easily manufactured, it is durable, it is of low costs and is particularly suitable for the t-piece of sport. The present invention thus has as an aim a body of fixing for a t-piece of sport, characterized by the fact that it includes/understands: - a base which is out of plastic and which has a connector having an external surface; a seat which is formed on and made covered starting from the external surface of the connector and which has an external surface; and a mounting tubular which is formed on and made covered starting from the external surface of the seat and having a shoulder of assembly which is formed on and made covered starting from the external surface of the seat and having a distal end; and a collar of assembly which is formed on and made covered starting from the distal end of 1 ' shoulder of

assembly and which has a distal end; and - a sleeve which is metal, being assembled around the collar of assembly of the base and having two ends. In accordance with particular characteristics of this invention: - the tubular mounting of the base can have moreover a cavity which is formed in the distal end of the shoulder of assembly and corresponding to the collar of assembly; and a body of stop which is larger than and which is formed on the distal end of the collar of assembly; and - one of the ends of the sleeve can be gone up in the cavity of tubular mounting and the other end of the sleeve can come into obstinate against the body from stop from tubular mounting. Other objectives, advantages and news characteristic of this invention will arise more easily with the reading of the following detailed description made in connection with the annexed drawings. On these drawings - Figure 1 is a sight in prospect for a body for fixing for a t-piece of sport in conformity with the present invention; - figure 2 is a sight in operational prospect for the body for fixing for Figure 1 with a sleeve which is represented in mixed features; - figure 3 is a side sight out of cut partial of the body of fixing of Figure 1; and - Figure 4 is a sight in operational prospect for the body for fixing for Figure 1, an elastic device having a target being assembled on the body of fixing. If one refers on Figure 1, one can see that a body of fixing for a t-piece of sport conforms to the present invention can be fixed at a floor, a wall, a ceiling, a support or similar and includes/understands a base and a sleeve 20. Base 10 is out of plastic and present a connector 11, a seat 12 and one tubular mounting 13. Connector 11 is fixed at the floor, the wall, the ceiling, the support or similar and has an external surface. Seat 12 is formed on and made covered starting from the external surface of connector 11 and has an external surface. If one refers again to Figures 2 and 3, one can see that tubular mounting 13 is formed on and made covered starting from the external surface of seat 12, presents a shoulder of assembly 131 and one collar of assembly 132 and can present a cavity 133 and one body of stop 134. The shoulder of assembly 131 is formed on and made covered starting from the external surface of seat 12 and presents a distal end. The collar of assembly 132 is formed on and made covered starting from the distal end of 1 ' shoulder of assembly 131 and presents a distal end. Cavity 133 is formed in the distal end of the shoulder of assembly 131 and corresponds to the collar of assembly 132. The body of stop 134 is larger than and is formed on the distal end of the collar of assembly 132. Sleeve 20 is metal, is assembled around the collar of assembly 132 of base 10 and has two ends.

.
.
.

CLMEN 1 - Body of fixing for a t-piece of sport, characterized by the fact that it includes/understands: - a base (10) which is out of plastic and which has a connector (11) having an external surface; a seat (12) which is formed on and made covered starting from the external surface of the connector (11) and which has an external surface; and a tubular mounting (13) which is formed on and made covered starting from the external surface of the seat (12) and having a shoulder of assembly (131) which is formed on and made covered starting from the external surface of the seat (12) and having a distal end; and a collar of assembly (132) which is formed on and made covered starting from the distal end of 1 ' shoulder of assembly (131) and which has a distal end; and - a sleeve (20) which is metal, being assembled around the collar of assembly (132) of the base (10) and having two ends.

2 - Body of fixing according to claim 1, characterized by the fact that:
- the tubular mounting (13) of the base has moreover a cavity (133)

FRFULL

which is formed in the distal end of 1' shoulder of assembly (131) and corresponding to the collar of assembly (132); and a body of stop (134) which is larger than and which is formed on the distal end of the collar of assembly (132); and - one of the ends of the sleeve (20) is assembled in the cavity (133) of tubular mounting (13) and the other end of the sleeve (20) comes into obstinate against the body from stop (134) from tubular mounting (13).

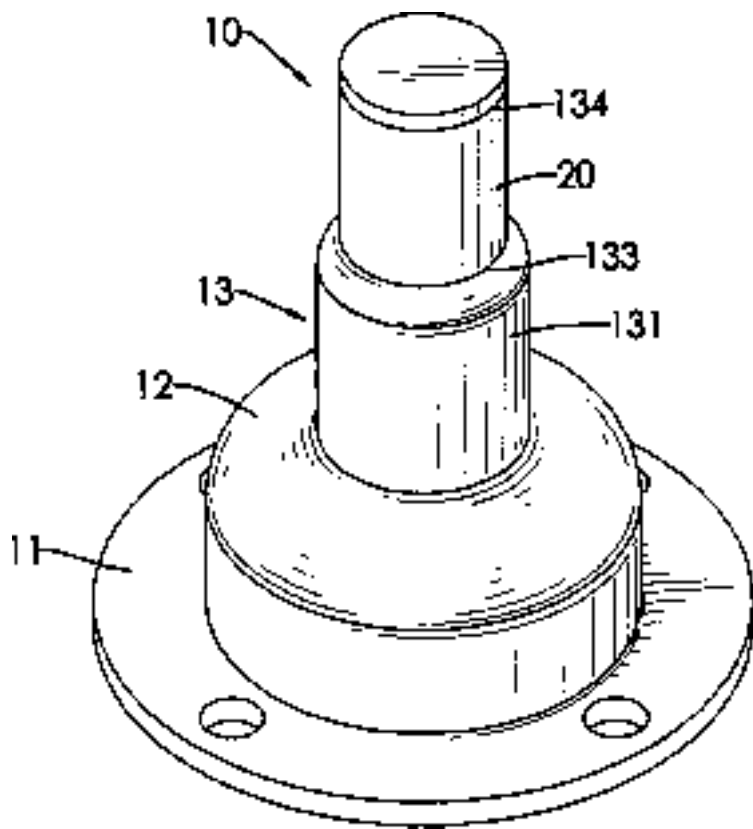
**In North America**

CAS
STN North America
P.O. Box 3012
Columbus, Ohio 43210-0012 U.S.A.

CAS Customer Center:
Phone: 800-753-4227 (North America)
614-447-3700 (worldwide)
Fax: 614-447-3751
E-mail: help@cas.org
Internet: www.cas.org

In Europe

FIZ Karlsruhe
STN Europe
P.O. Box 2465
76012 Karlsruhe
Germany
Phone: +49-7247-808-555
Fax: +49-7247-808-259
E-mail: helpdesk@fiz-karlsruhe.de
Internet: www.stn-international.com

In Japan

JAICI (Japan Association for
International Chemical Information)
STN Japan
Nakai Building
6-25-4 Honkomagome, Bunkyo-ku
Tokyo 113-0021, Japan
Phone: +81-3-5978-3601 (Technical Service)
+81-3-5978-3621 (Customer Service)
Fax: +81-3-5978-3600
E-mail: support@jaici.or.jp (Technical Service)
customer@jaici.or.jp (Customer Service)
Internet: www.jaici.or.jp